

Cube, strip & slice cutting machine KUJ V



High performance dicer
designed and constructed for the
food processing industry



Cube, strip and slice cutting machine KUJ V



Precise cutting for the finest dicing, slicing and strip cutting of your most delicate products!

The KRONEN high performance dicer **KUJ V** cuts slices from 2 up to 12 mm, strips from 2 up to 20 mm and cubes from 3 up to 20 mm in precise, perfect cutting quality. It can process up to 3.000 kg per hour.

High quality accessories enable neat slicing without damaging the produce. Even delicate products (such as onions, peppers, mushrooms, tomatoes, zucchini or slightly frozen products) can be processed. A frequency converter with 7 adjustable speeds allow the gentle cutting of very sensitive products like e.g. strawberries or beetroot, etc.

In addition to larger cubes cut from apples, melons, ham, cooked chilled meat and a variety of vegetables, tiny cubes as small as 3 x 3 mm (Brunoise) can be cut.

The **KUJ V** can cut strips as small as 2 x 2 mm in section for dips, soups, sauces, salads and much more.

Our standard – the benefits:

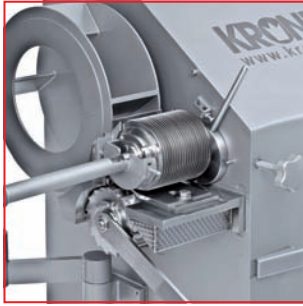

Simple change of spindles

One of the most appealing advantages of the KUJ V dicer is the easy and fast mounting and dismounting of the spindles, which allows you to switch products quickly and saves time in cleaning.

Special tools, delivered with the machine, guarantee a change of the cutting tools in a simple, quick and safe way within minutes.



Low maintenance costs due to exchangeable blades

To ensure a constant perfect cut and to reduce costs all blades can be resharpened or individually replaced.



Easy maintenance and hygiene

Hygiene is of utmost importance for food processing machines. Central lubrication and an easy accessible housing facilitate maintenance and service operations.

The KUJ V is completely made of stainless steel. The ergonomic KRONEN design with integrated switch box, seamless edges, 90° swivelling cutting chamber door and water connection are major advantages and standard features.



FDA approved

All parts that are in contact with food are made of stainless steel or FDA approved plastic, i.e. all of the KUJ V is FDA approved. FDA approval is documented in manual supplied with machine.

Options and accessories at a glance



Wide range of cutting inserts also for non-standard requirements

A cutting insert consists of:

- grooved knife, steplessly adjustable from 2 to 20 mm, for the first cut
- circular knives spindle (with scraper), available in 2-3-5-6-7.5-9-10-12-15-20-30 mm, for the second cut
- cross cut spindle, available in 3-5-7.5-10-12-15, 20, 40 mm, for the third cut

Combination of knives allows various cutting forms, e.g.:

6 x 10 x 15 mm 4 x 5 x 7.5 mm 3 x 3 x 3 mm 3 x 5 x 5 mm and many more

Special cutting inserts for wave cut can be provided, as well as for particular products such as pineapples.



Useful holder for cutting accessories and tools

The movable holder is a „must-have“ for fast, useful and safe storing of the valuable cutting accessories and tools.

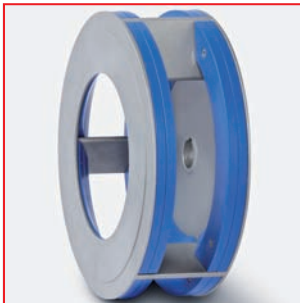

Adjustable product infeed for long-shaped products

For improving the infeed of long-shaped products like carrots and producing longer strips / batonnets, the 3-wing rotor is perfectly suited.

4 plastic spacers reduce the max. possible product diameter from 90 to 80, 70, 60 or 50 mm to assure a better guiding to the first cut.

The reduction of the rotor from 4 to 3 chambers increases the possible product length from 140 to 220 mm.



Feeding hopper

For easier loading of the KIJ V with product out of baskets or crates. The removable loading funnel allows loading of the KIJ V from both sides and from the back.



Automation

We also provide product feed and discharge belts to make the production process more effective.

Technical drawings & specifications

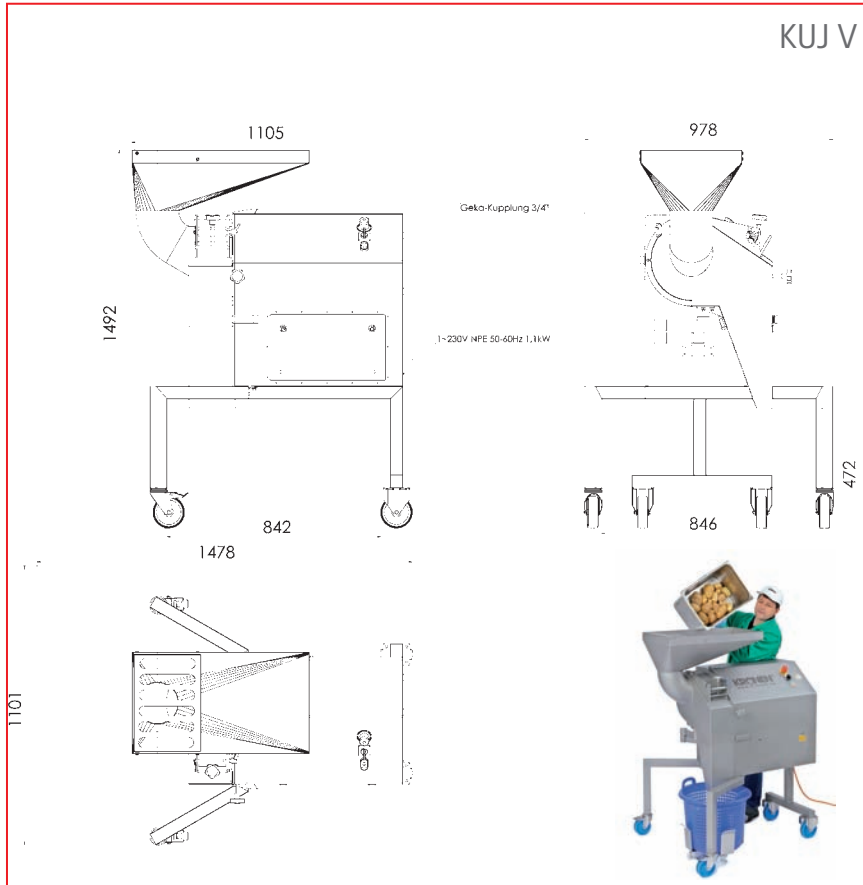

measures	
length	1105 mm
width	978 mm
height	1492 mm
weight	260 kg
water connection	3/4 "
capacity	up to 3000 kg / h
e.g. carrots	5 x 5 mm 1000 kg / h
	15 x 15 mm 2000 kg / h
	20 x 20 mm 3000 kg / h
max. product width	90 mm
max. product length	220 mm
max. product diam. chute pipe	150 mm
power	
total power	1.1 kW
voltage	230 V N/PE
frequency	50/60 Hz



The high capacity KUJ V cube, strip and slice cutting machine can be integrated perfectly into a professional production line.

With an effective combination of single machines we successfully implement production processes and customized processing lines by the use of state-of-the-art control and measurement technology.

Product Range:

- **Belt cutting machines**
GS 10, GS 20, GS 25, GS 25V
- **Slice and wedge cutters**
Tona S180K, Tona S, Tona E
- **Special cutting and punching machines**
Tona Rapid, Tona Rapid 3D, Tona Rapid XL, Multicorer, Multislicer, TT 450
- **Cube and strip cutter** KUJ V
- **Multi purpose cutting machine** SN 100
- **Cabbage cutting machine** CAP 68
- **Cabbage corer** KSB
- **Dicing, wedging & shaping machine** PGW, HGW
- **Vegetable and salad washing equipment**
- **Peeling machines**
for citrus fruit, melons, apples, potatoes carrots, celery, etc.
- **Centrifuges**
- **Packaging machines**
- **Special machines**
- **Complete production lines**



We develop and manufacture single and special machines as well as complete processing lines for the food processing industry.

We successfully implement production processes for you by effectively combining single machines.

KRONEN - smart solutions and convincing technology for the food processing industry!



KRONEN GmbH

Römerstraße 2a
77694 Kehl am Rhein / Germany
Phone: +49 (0) 7854/96 46-0
Fax: +49 (0) 7854/96 46-50
info@kronen.eu