

Branding by Banding Model

Design meets sustainability

- › High performance labelling with state-of-the-art positioning technology
- › Printed banding displays your product to its best for optimum shelf appeal
- › Brand, label, seal and tell your story as you like it
- › Reduce packaging volumes with sustainable banding

All Bandall equipment is of pure Dutch design, engineering and manufacture. Our Branding by Banding Model is durable, industrial banding equipment, from flexible stand-alone mobile units to fully automatic and in-line bespoke solutions. Often replacing excessive or complex packaging, banding is a sustainable option. Materials include FSC certified paper and 100% recyclable film.



Brand, label, seal and tell your story as you like it

Branding by Banding Model:

- › All your **branding, product details and storytelling** on a single neat band
- › Rapid and reliable processing with **high-tech band transport technology**
- › One machine processes a **wide selection of materials**
- › **Consistent accurate positioning** on each and every product
- › Unique **UCS (Ultra Clean Seal) system** guarantees a hygienic and safe seal
- › Low energy, maintenance and operational costs - Bandall continues to guarantee **the lowest cost of ownership**

Multiple band widths with one machine - easy accessibility for roll change

Print unlimited variable data during application



100% precision banding

The Branding by Banding Model performs with outstanding precision and reliability. The high-tech band transport system guarantees rapid band transport around the arch and consistently accurate application.

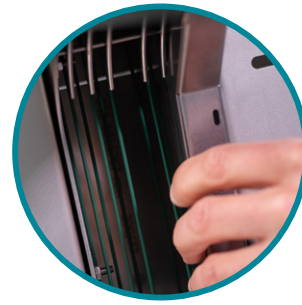

NEW OPTION:
Easy click system
to change the
band width

Bandall systems are designed for user-friendly and efficient operation. The Branding by Banding Model includes:

- › A **touch screen control** panel with symbols – language free
- › Activation of the banding cycle via a **product sensor, a button or a foot switch**
- › **Operation from both sides** of the machine
- › A choice of **standard band widths**: 28, 40, 48, 60, 75, 100 and 125 mm. Alternative band widths upon request
- › **Adjustable product guides**
- › **Precision tension adjustment**
- › **Mobile machine**, on castors with brakes
- › **Options** such as multiple band widths, thermal transfer printer, bundle press
- › A wide selection of **fully automatic models** and bespoke solutions

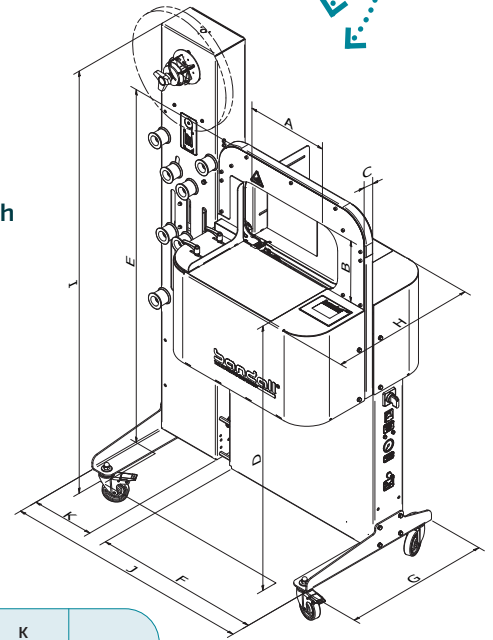

MACHINE TYPE	A Max. prod. width	B Max. prod. height	C Channel width	D Work height	E Height	F Width	G Base depth	H* Depth	I Total height	J** Total width	K Width of external reetholder	Cycles/min. ***
BA24/15-30	240	150	30	955	1220	600	500	500	1505	840	220	36
BA32/20-30	320	200	30	955	1270	600	500	500	1505	840	220	34
BA40/25-30	400	250	30	955	1320	760	500	500	1505	1000	220	32
BA48/30-30	480	300	30	955	1370	760	500	500	1505	1000	220	30

* With a channel width of 50 mm, H is 520 mm. With a channel width of 77 mm, H is 547 mm. With a channel width of 102 mm, H is 572 mm. With a channel width of 127 mm, H is 597 mm.
** With a positioning system fitted, J is 130 mm wider.
*** With positioned bands the capacity is about 18 to 20 bands per minute, dependent upon the product to be banded.
Sizes in mm.

Voltage	230V/115V
Frequency	50 HZ/60HZ
Required air pressure	Min 6 bar, max 10 bar
Air consumption	max. 60 L/min.
Power	500 watts



bandall[®]
THE STANDARD IN BANDING

BANDALL B.V. Damzigt 45, 3454 PS De Meern - Utrecht, The Netherlands
T +31 (0)348 431520 F +31 (0)348 431480 E info@bandall.com I bandall.com



EE/OE